



INSTALLATION MANUAL

ONE2CLEAN TANKS



Safety

The relevant accident prevention regulations must be observed during all work. Particularly when walking on the tanks, a 2nd person is required to secure the tank.

The relevant regulations and standards must additionally be taken into consideration during installation, assembly, servicing, repair, etc.

The system or individual parts of the system must be installed by qualified specialists.

During all work on the system or parts of the system, the entire system must always be rendered inoperable and secured to prevent unauthorised reactivation. Except in the event of work carried out in the tank, the cover of the tank must always be kept sealed, as this otherwise constitutes a maximum risk of accident. Only original GRAF covers or covers approved in writing by GRAF must be used.

GRAF offers an extensive range of accessories, all of which are designed to match each other and which can be extended to form complete systems.

The use of other accessories may lead to impediments to the system's functional capability, therefore invalidating liability for resulting damage.

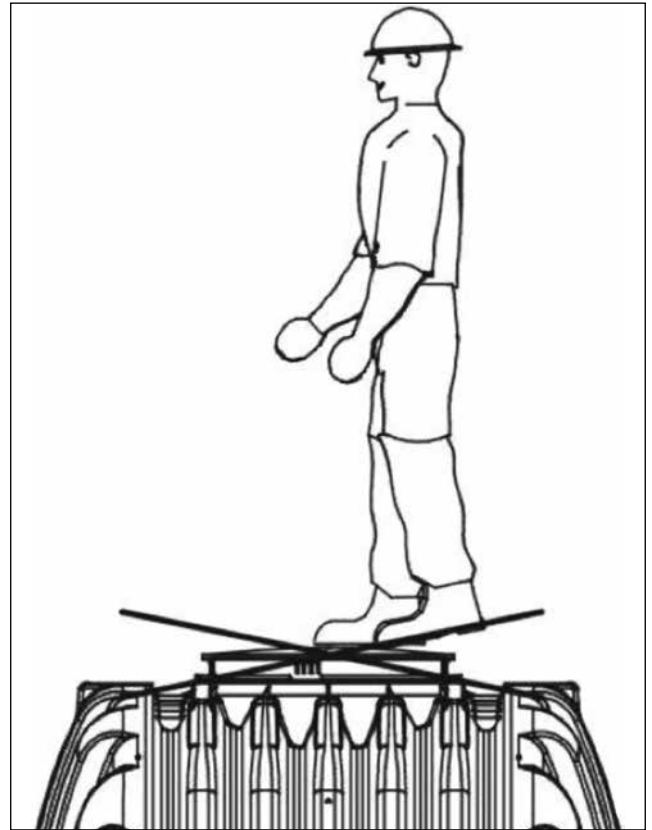

Coverage heights with telescopic dome shaft in green areas.

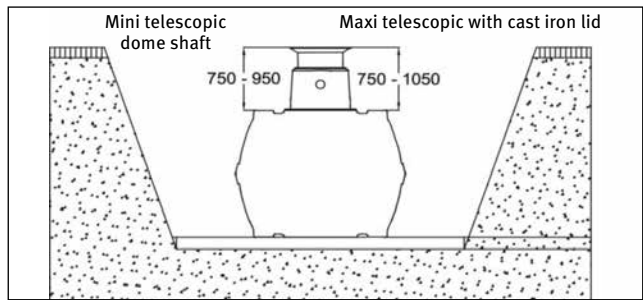

Maximum coverage heights with extensions and telescopic dome shaft.

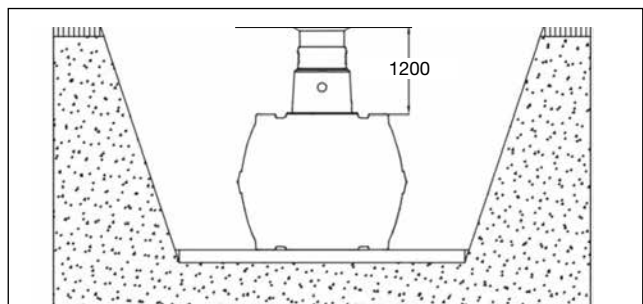

Covering heights with cast telescopic dome shaft (with class B cast cover) in areas with car traffic (load up to 3.5 t).

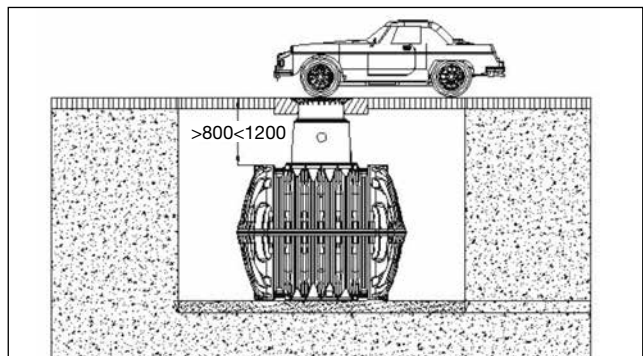

Coverage heights with vehicle loading cover (suitable cover to be provided by others) in areas used by trucks with a max. weight of 12 t.

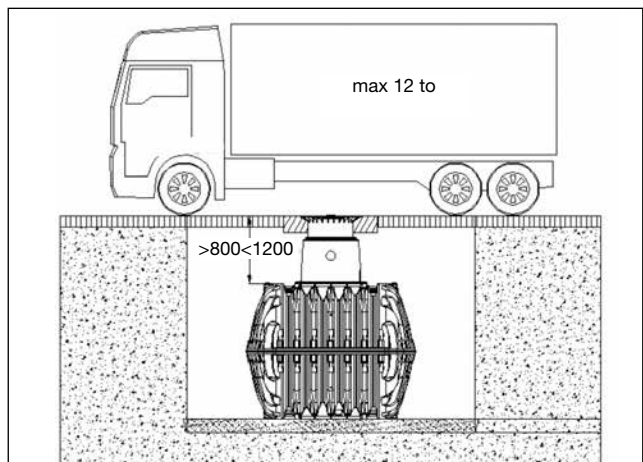

Coverage heights on installation in groundwater the hatched area specifies the permissible immersion depth for the tanks.

The immersion depth is 350 mm.

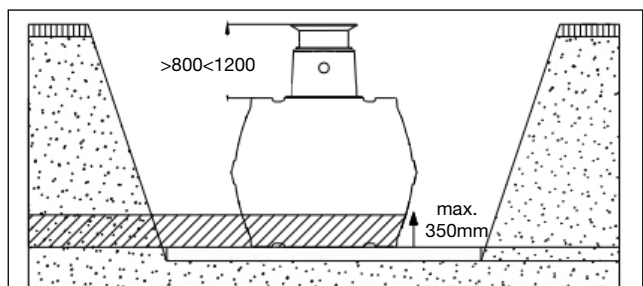

With mini tank dome

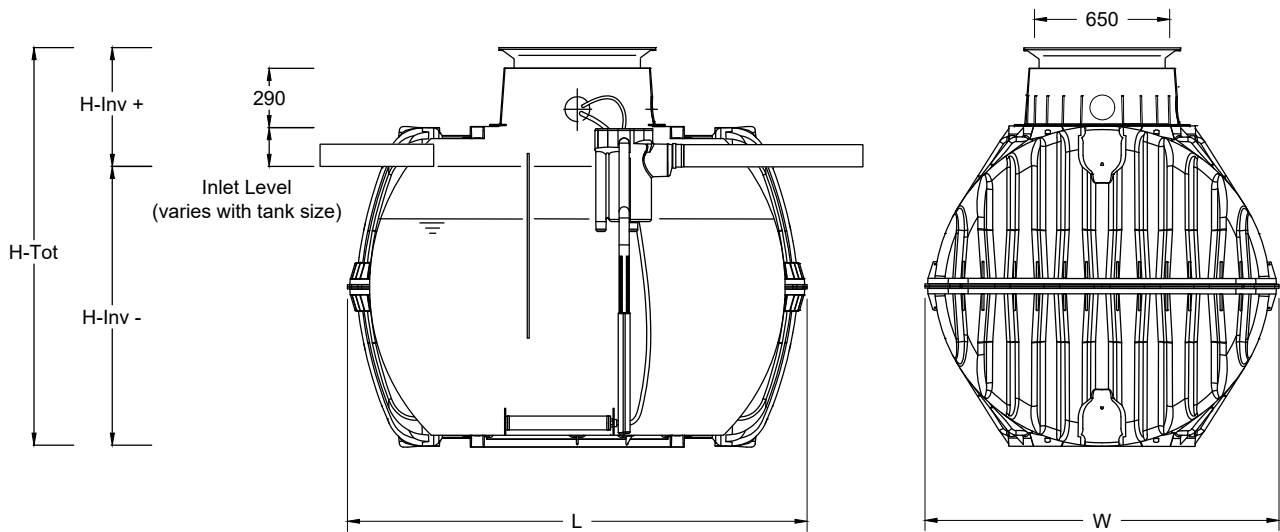

With maxi tank dome

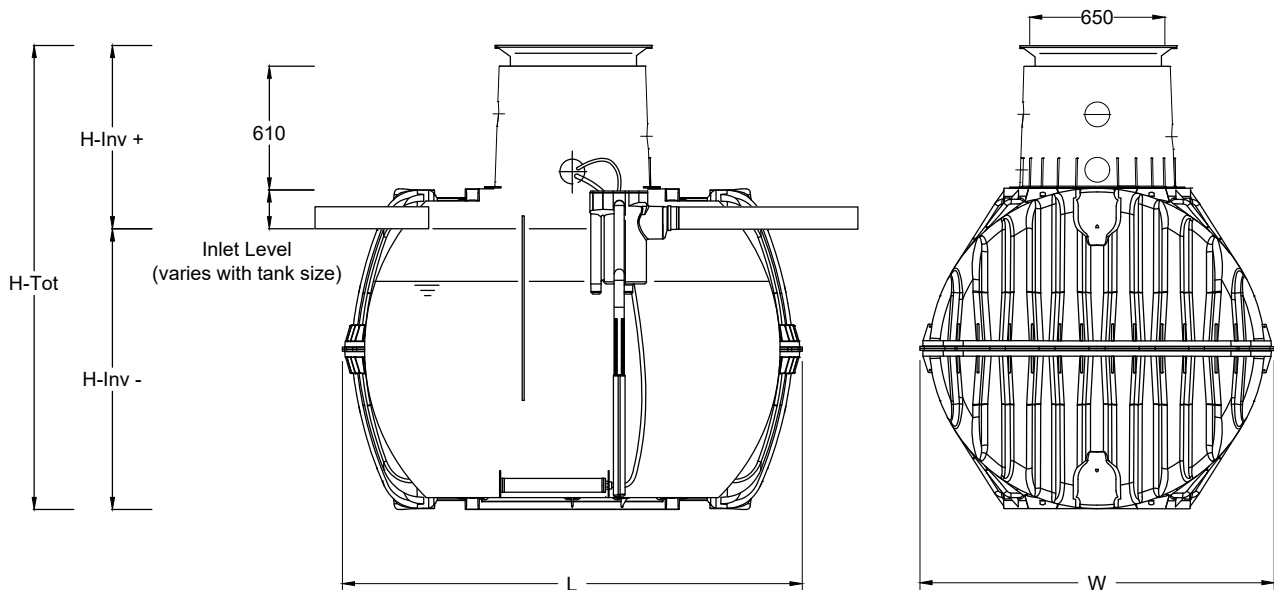

* Various inlet options available to suit installation. Please specify invert depth required when ordering.

Population Equivalent	5 PE	7 PE	9 PE
Tank	3750 litres	4800 litres	6500 litres
Max. daily inflow	750 l/d	1050 l/d	1350 l/d
Weight with mini tank dome	146kg	181kg	220kg
Weight with maxi tank dome	150kg	185kg	220kg
L	2280mm	2280mm	2390mm
W	1755mm	1985 mm	2190mm
H-Inv -	1390mm	1575mm	1840mm
H-Inv + *	630 to 1460mm		
H-Tot	2020 to 2790mm	2250 to 3020mm	2530 to 3300mm

4 TANK INSTALLATION

1. Subsoil
2. Telescopic dome shaft
3. Compact foundation
4. Surrounding (round-grained gravel, maximum grain size 10 to 20mm)
5. Covering layer
6. Carat underground tank
7. Concrete layer for surfaces used by passenger cars

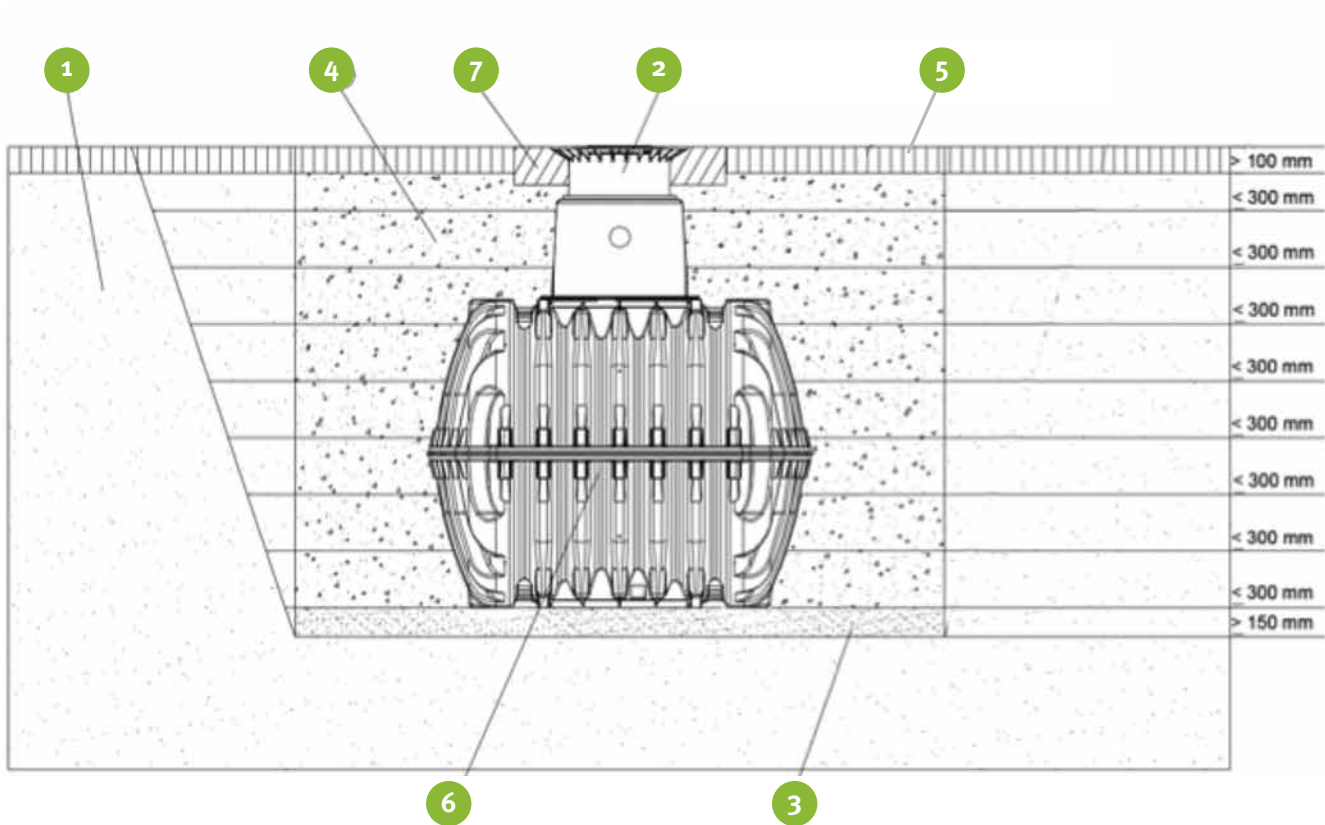

Trench

To ensure that sufficient space is available for working, the base area of the trench must exceed the dimensions of the tank by 500mm on each side; the distance from solid constructions must be at least 1000mm.

The trench embankment must be designed so that slippage or collapse of the embankment wall is not to be anticipated. The construction site must be horizontal and plane and must guarantee sufficient loadbearing capacity.

The depth of the trench must be dimensioned so that the max. earth coverage (see point 2 installation conditions) above the tank is not exceeded. To use the system throughout the entire year, it is necessary to install the tank and those parts of the system which conduct water in the frost-free area. The frost-free depth is usually approx. 600mm to 800mm; precise information in this regard can be obtained from the responsible authority.

A layer of compacted, round-grain gravel (grain size 10 to 20mm, thickness approx. 150 - 200mm) is applied as the foundation.

Slope, embankment, etc.

On installation of the tank in the immediate vicinity (< 5m) of a slope, earthen mound or slope, a statically calculated supporting wall must be erected to absorb the soil pressure. The wall must exceed the dimensions of the tank by at least 500mm in all directions, and must be located at least 1000mm away from the tank.

Groundwater and cohesive (water-impermeable) soils (e.g. clay soil)

If it is anticipated that the tanks will be immersed deeper into the groundwater than is shown in the adjacent figure, sufficient dissipation must be ensured. (See table for max. immersion depth).

Dissipation of the drainage water (e.g. via an annular drainage system) is recommended in the case of cohesive, water-impermeable soils.

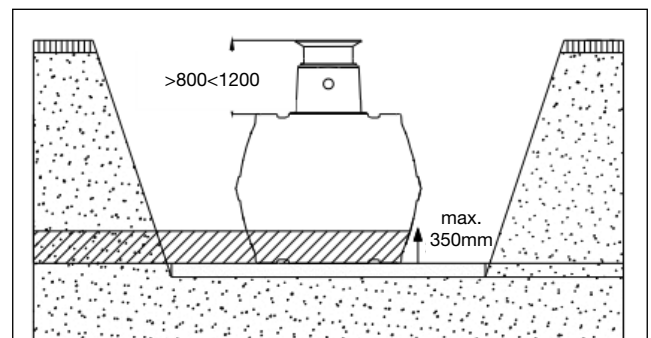
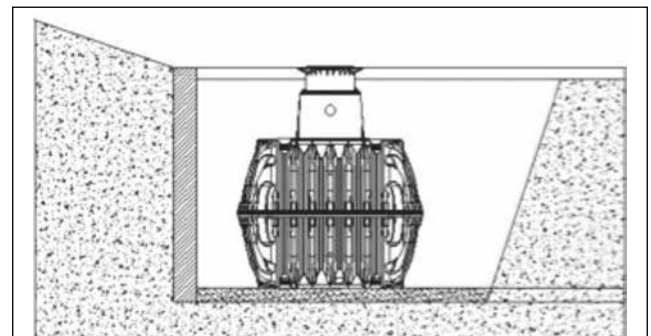

Population Equivalent	5 PE	7 PE	9 PE
Tank size	3750	4800 L	6500
Immersion depth	350mm	350mm	350mm

Installation adjacent to surfaces used by vehicles

If the underground tanks are installed adjacent to surfaces which are used by vehicles heavier than passenger cars, the minimum distance away from these surfaces is at least the depth of the trench.

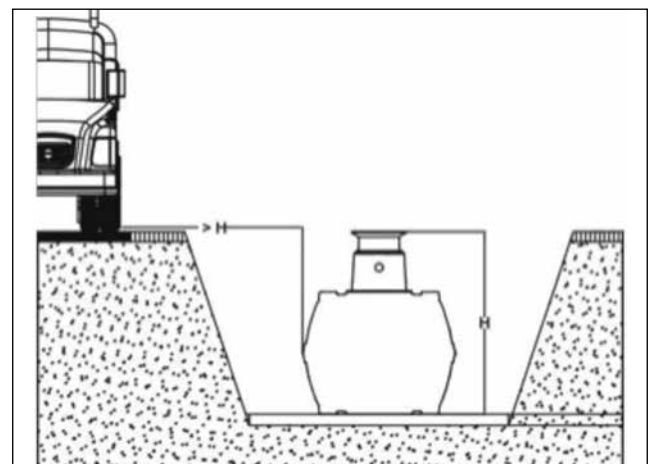

Insertion and filling

The tanks must be inserted, impact-free, into the prepared trench using suitable equipment. The tank is filled with $\frac{1}{3}$ water before starting to backfill.

Afterwards the surrounding (roundgrain gravel, max. grain size 10 to 20mm) is then filled in layers of max. 30 cm steps and is compacted. The individual layers should be manually tampered to ensure no voids. Damage to the tank must be avoided during compaction. Mechanical compaction machines must not be used under any circumstances. The surrounding must be at least 500mm wide.

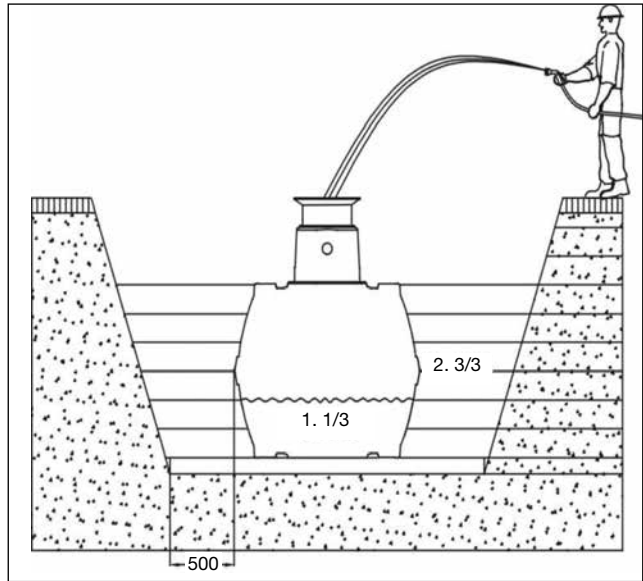

Ventilation and bleeding

Poor venting and the lack of a Soil Vent Pipe is the number one cause of smells from treatment plants. All tanks must be ventilated and bled back through the soil vent pipe (chimney effect). Air Admittance Valves (Durgo Valves) must not be used instead of the SVP. These valves are fine for houses connected to mains drainage but NOT for ones with a treatment plant.

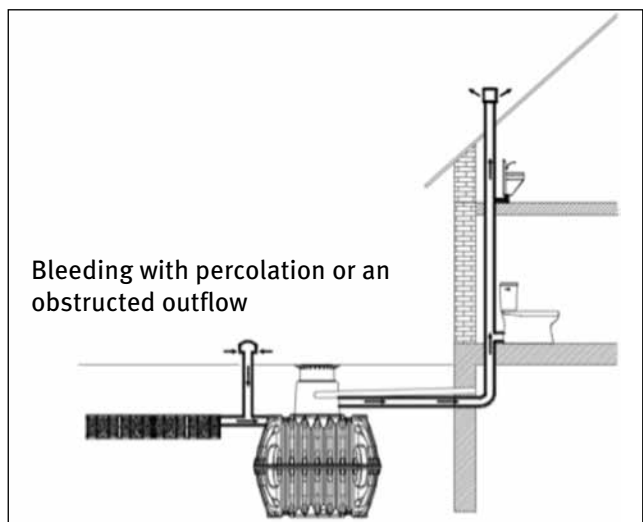
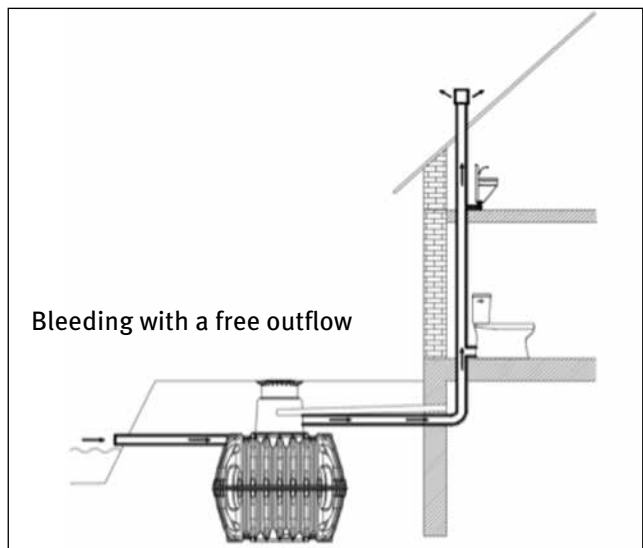

Assembling the telescopic dome shaft

The telescopic dome shaft enables infinite adaptation of the tank to given site surfaces with earth coverage of between 750mm and 950mm (Mini telescopic dome shaft) or 750mm and 1050mm (Maxi telescopic dome shaft).

For assembly purposes, the enclosed profile seal (material EPDM) is inserted into the tank dome's sealing groove and is coated generously with soft soap (do not use mineral oil-based lubricants, as these attack the seal). The telescope is then greased, inserted and aligned with the surface of the site.

Telescopic dome shaft on which persons may walk

Important: To prevent loads from being transferred onto the tank, round-grain gravel ① (max. grain size 10 to 20mm) is filled in in layers around the telescope ② and is evenly compacted.

Damage to the tank dome ③ and telescope must be avoided during this step. The cover is then positioned and is sealed to prevent entry by children. **Tighten the threaded connection on the cover so tightly that it cannot be opened by a child!**

Telescopic dome shaft over which passenger cars may drive

If the tank is installed under areas used by passenger cars, the collar area of the telescope ① (colour anthracite) must be supported with concrete ④ (load class B25 = 250 kg/m²). The layer of concrete to be installed must be at least 300mm wide and approx. 200 mm high all around. The minimum coverage above the shoulder of the tank is at least 800mm (max. 1050mm with telescope, coverage up to max. 1200mm possible with intermediate section).

Attention: It is essential to use the cast telescopic dome shaft (with class B cast cover).

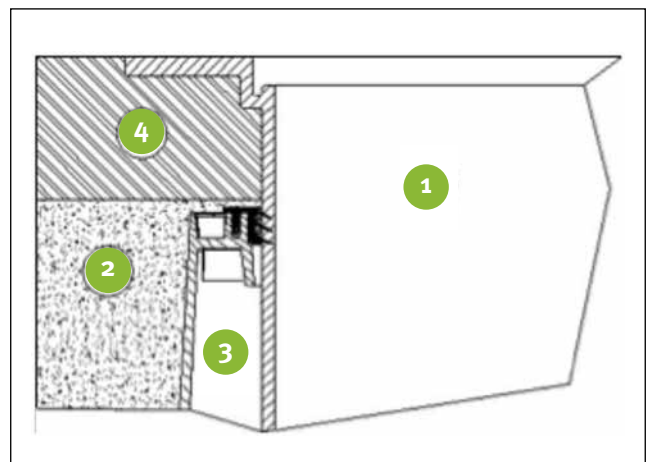
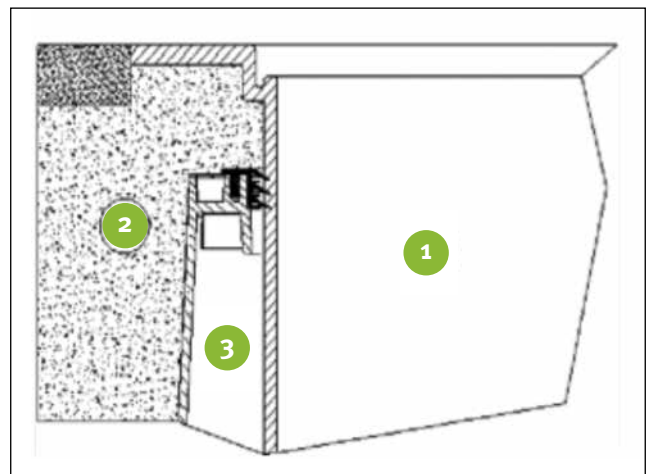
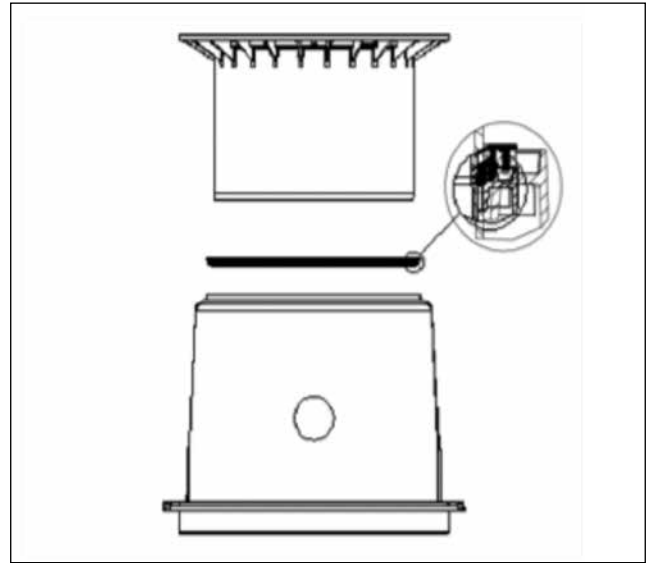

Assembling the extension

For larger coverage heights an extension is needed. To insert the extension into the tank dome, soft soap is needed. Into the highest groove of the extension the profile seal is inserted and greased generously. Afterwards push the telescopic dome shaft into the extension and adapt it to the planned area surface. The extension must not be cut down.

1 Extension = max. earth-cover 1200mm
(in each case in connection with the Maxi telescopic dome shaft)

- ① Telescopic dome shaft (can be inclined by 5°)
- ② Extension
- ③ Tank dome (can be rotated by 360°)

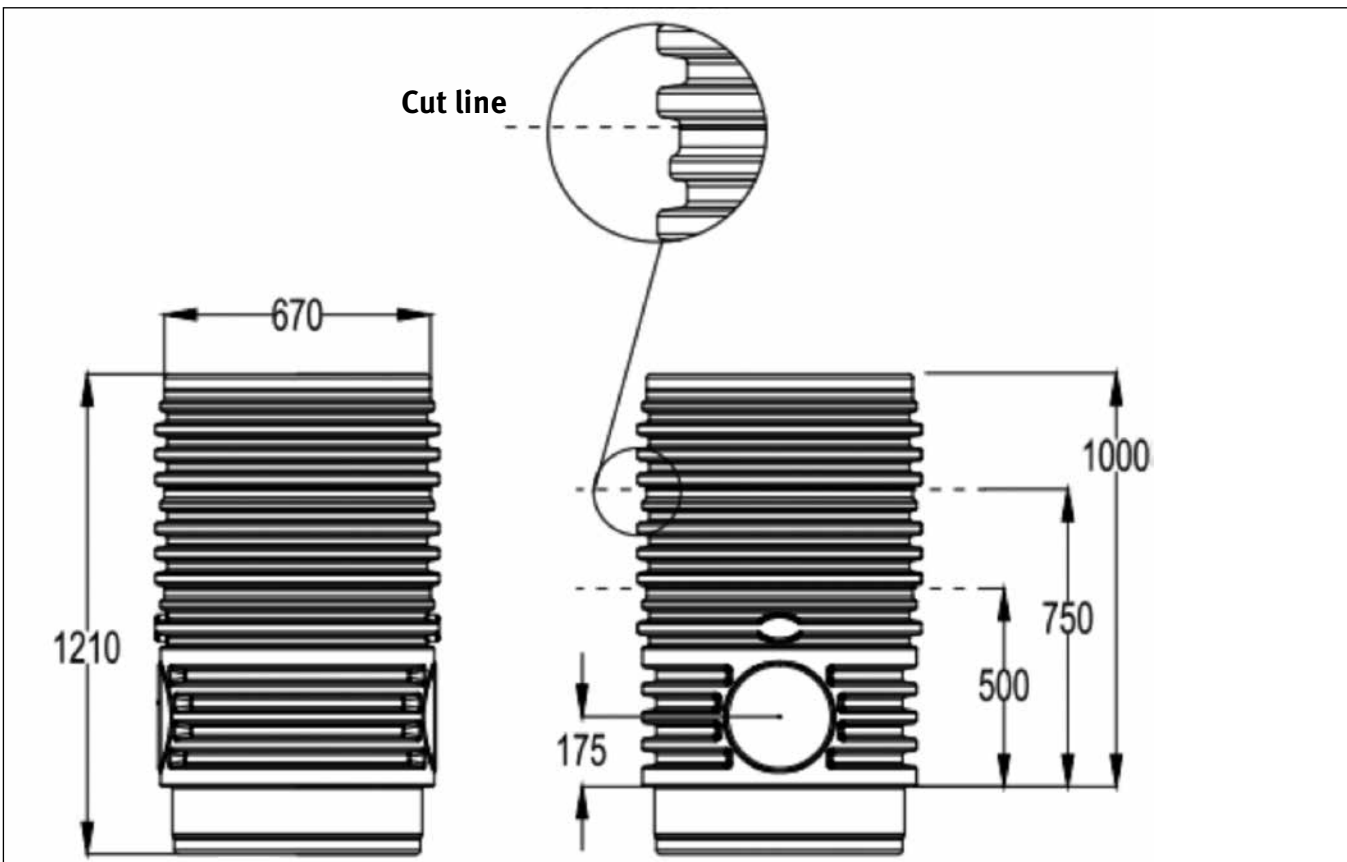
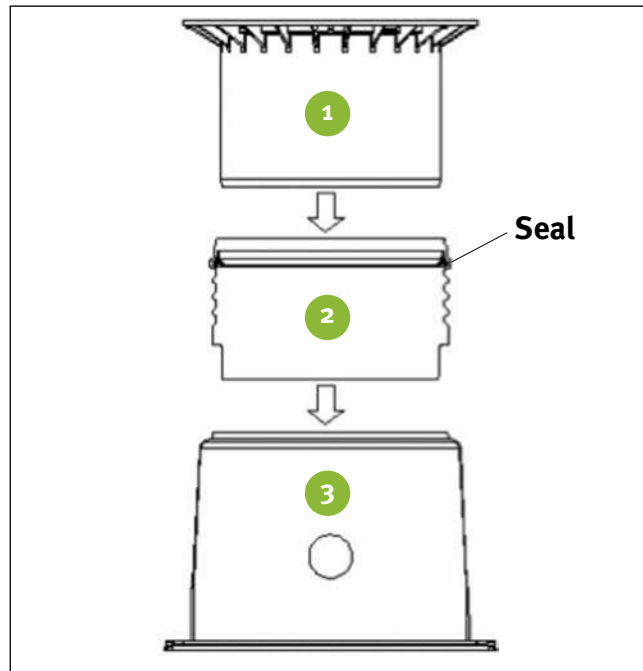

THIS DOCUMENT IS SUPPLIED IN STRICT CONFIDENCE AND MUST NOT BE LENT, REPRODUCED OR DISCLOSED TO ANY THIRD PARTY WITHOUT THE WRITTEN CONSENT OF SCP WATER MANAGEMENT LIMITED
DO NOT SCALE - IF IN DOUBT ASK

NOTES:-

PO	FOR GUIDANCE	DS	07.10.20
REV	DESCRIPTION	BY	DATE
ISSUE			

GRAF **GRAF UK Limited**
 Graf UK Limited | Regen House | Beaumont Road | Banbury | OX16 1RH
 T: 01608 661500 F: 01285 211333
 E: info@grafuk.co.uk www.grafuk.co.uk

DRAWN	DS	DATE	07.10.20
CHECKED	MC	SCALE	N/A
PROJECT			

PROJECT: ONE2CLEAN

DESCRIPTION: INTERNAL CABINET

DRAWING NO.	REV.
ONE2CLEAN_INTERNAL CABINET	P0

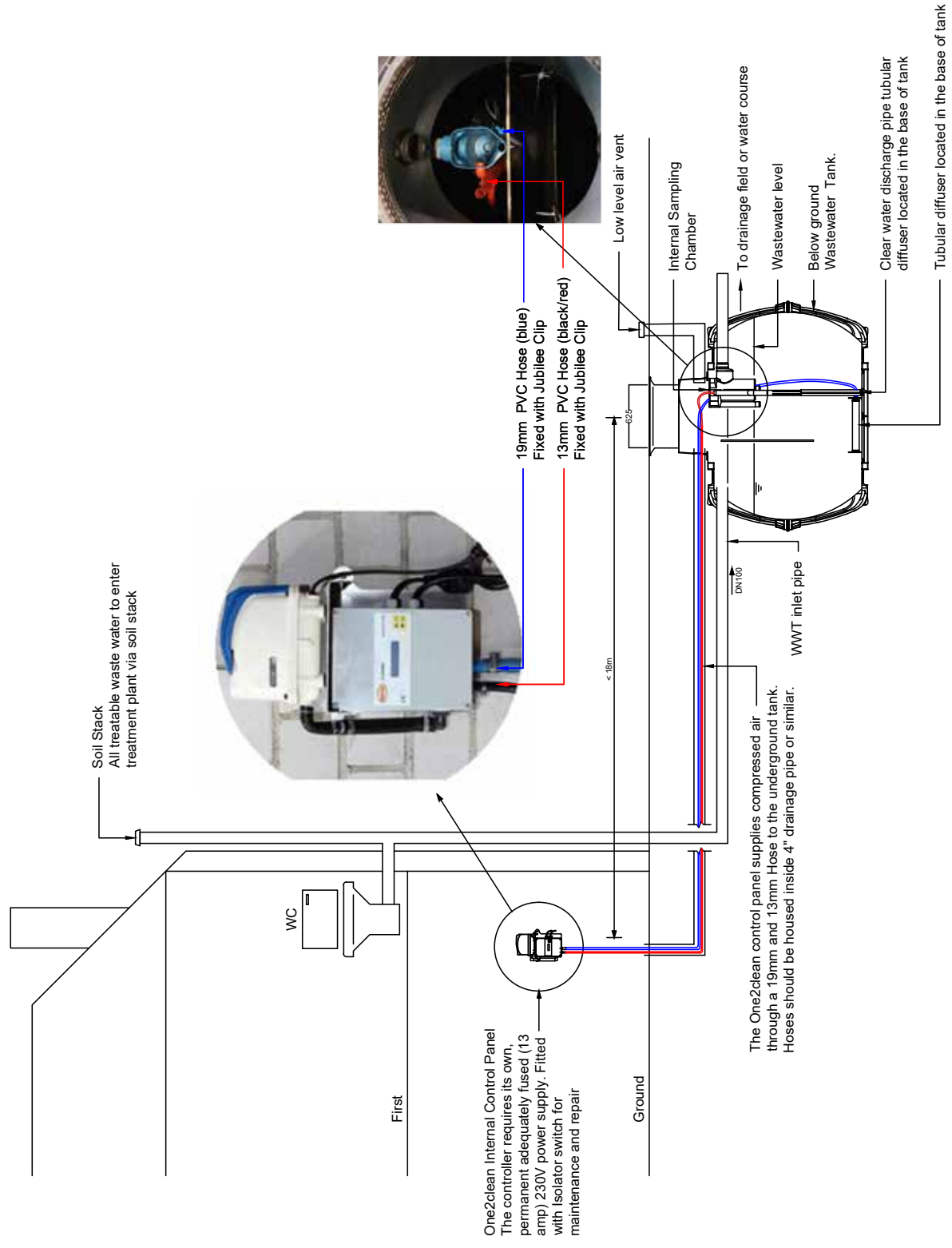

THIS DOCUMENT IS SUPPLIED IN STRICT CONFIDENCE AND MUST NOT BE LENT, REPRODUCED OR DISCLOSED TO ANY THIRD PARTY WITHOUT THE WRITTEN CONSENT OF SOP WATER MANAGEMENT LIMITED

DO NOT SCALE - IF IN DOUBT ASK

NOTES:-

P0	FOR GUIDANCE	DS	07.10.20
REV.	DESCRIPTION	BY	DATE

ISSUE



DRAWN: DS
CHECKED: MC
DATE: 07.10.20
SCALE: NTS@A3

PROJECT
ONE2CLEAN

DESCRIPTION
EXTERNAL CABINET

DRAWING NO.
ONE2CLEAN_EXTERNAL_CABINET_P0
REV.

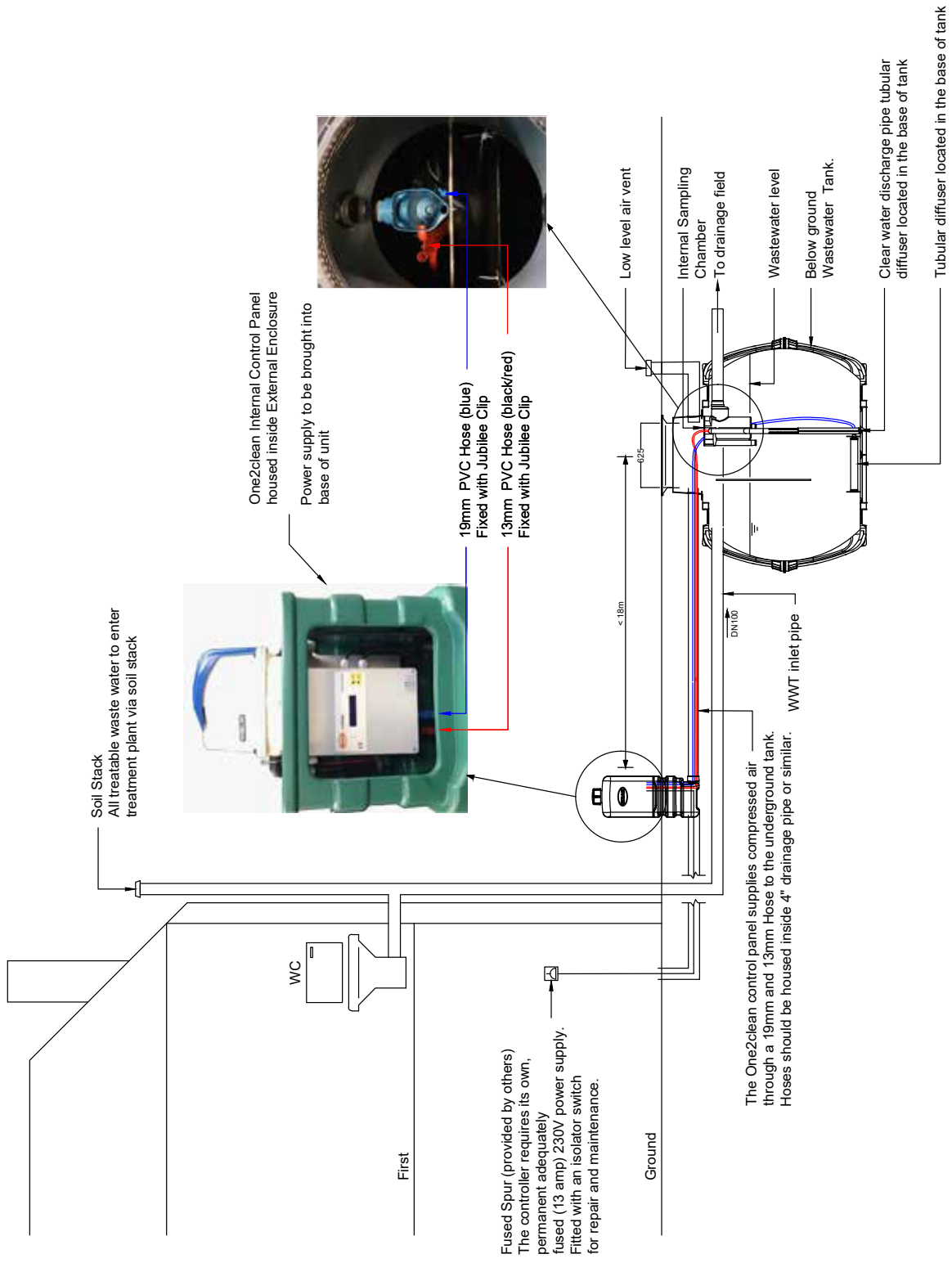

6. EXTERNAL CABINET

THIS DOCUMENT IS SUPPLIED IN STRICT CONFIDENCE AND MUST NOT BE LENT, REPRODUCED OR DISCLOSED TO ANY THIRD PARTY WITHOUT THE WRITTEN CONSENT OF GRAF UK LIMITED.

DO NOT SCALE - IF IN DOUBT ASK

GRAF ONE2CLEAN SYSTEM OPTIONS:

- 3750 LITRE CARAT TANK - 5 PE TREATMENT PLANT
- 4800 LITRE CARAT TANK - 7 PE TREATMENT PLANT
- 6500 LITRE CARAT TANK - 9 PE TREATMENT PLANT

SCOPE OF SUPPLY:

- GRAF ONE2CLEAN WASTEWATER SYSTEM SUPPLIED WITHIN CARAT TANK
- AIR DIFFUSERS IN BASE OF TANK
- CLEAR WATER AIR LIFTER
- INTEGRATED SAMPLING CHAMBER
- TELESCOPIC LID, SUITABLE FOR EITHER PEDESTRIAN OR VEHICLE LOADING REQUIREMENTS
- FLEXIBLE HOSES TO BRING AIR INTO THE TANK FOR SYSTEM OPERATION
- INTERNAL SYSTEM CONTROL PANEL WITH DISPLAY AND OPERATIONAL BUTTONS TO SUPPORT COMPRESSOR

OPTIONAL:
(EPP) EXTERNAL HOUSING ENCLOSURE FOR INTERNAL SYSTEM CONTROL PANEL

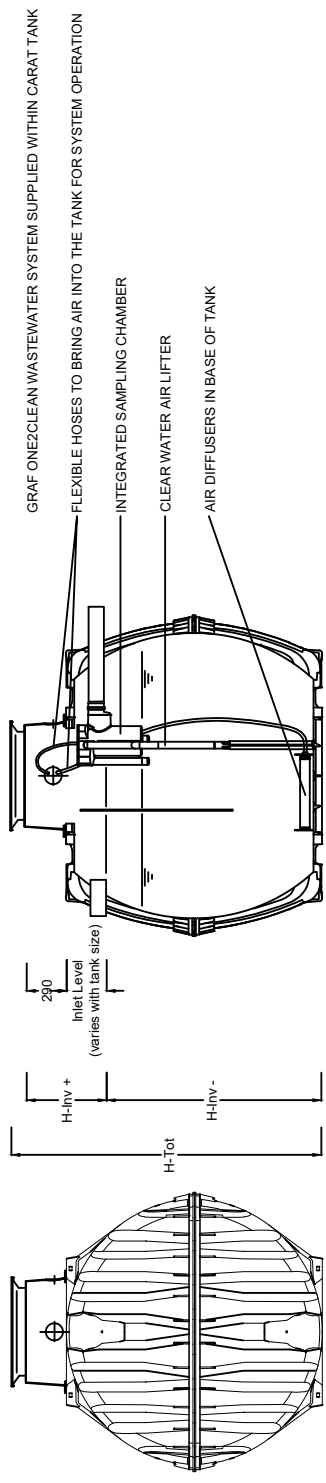

INTERNAL SYSTEM CONTROL PANEL WITH DISPLAY AND OPERATIONAL BUTTONS TO SUPPORT COMPRESSOR

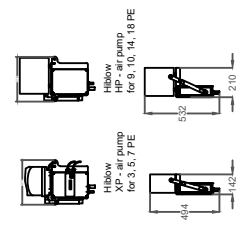

(EPP) EXTERNAL HOUSING ENCLOSURE FOR INTERNAL SYSTEM CONTROL PANEL

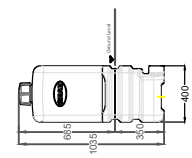

TELESCOPIC LID, SUITABLE FOR EITHER PEDESTRIAN OR VEHICLE LOADING REQUIREMENTS

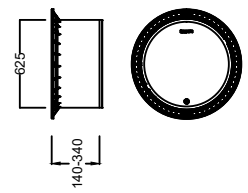

Population	3750 litres	4800 litres	6500 litres
Structure	5 Structures	7 Structures	9 Structures
Weight	44kg	88kg	220kg
Length (L)	220mm	220mm	230mm
Width (W)	175mm	195mm	210mm
H-Hw -	130mm	155mm	180mm
H-Hw +	490mm	530mm	550mm
H-Tot	200-290mm	250-300mm	250-300mm

PO	FOR GUIDANCE	DS	14.08.20
REV	DESCRIPTION	BY	DATE

GRAF GRAF UK Limited
 Graf UK Limited | Regen House | Beaumont Road | Banbury | OX16 1RH
 T: 01608 661500 F: 01295 211333
 E: info@grafuk.co.uk www.grafuk.co.uk

DRAWN: DSI DATE: 14.08.20
 CHECKED: - SCALE: NTS/A3

DESCRIPTION

GRAF ONE2CLEAN

REV P0



D	Steuerung one2 clean XP und HP Version	Artikel-Nr. article no.
GB	control unit one2clean model XP and HP	FR

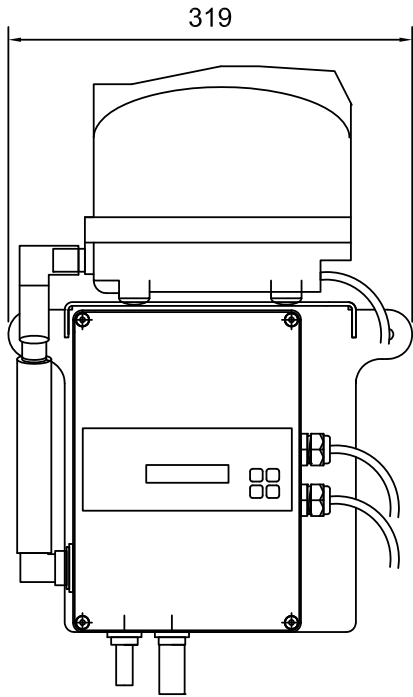

Hiblow
XP - air pump
for 3, 5, 7 PE

Hiblow
HP - air pump
for 9, 10, 14, 18 PE

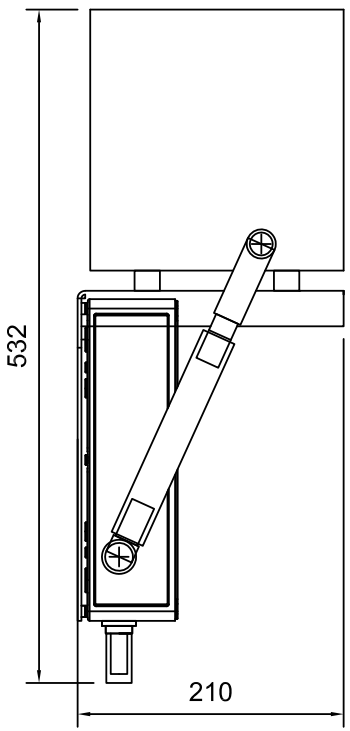
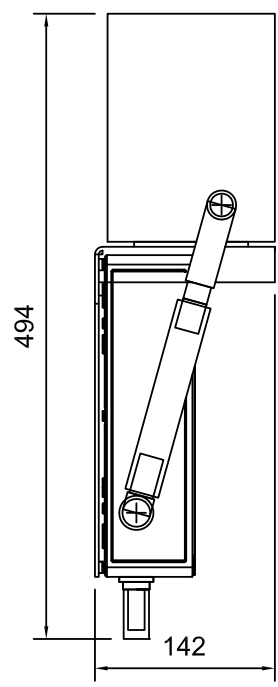

M:\Produktmanagement\... Projekte 2011\1P12-024 - easyOne\Maßzeichnungen\Steuerung\MSZ_one2clean Steuerung.dwg 2014-04-10

Otto Graf GmbH Carl-Zeiss-Str. 2-6 DE-79331 Teningen Germany info@graf.info www.graf.info	Zeichnungsinformation drawing information	Artikelinformation article information	Alle Maßangaben in mm all dimension in mm	
	gezeichnet drawn	CSC		Gewicht weight
	Datum date	09.04.2014		
	Toleranz tolerance	+/- 3 %		

9

INSTALLATION OF AIR HOSES AND EXTERNAL CONTROLLER

* Must be installed within 18m of tank. (Air hoses are 20m in length)



1

Connect 13mm hose here

Connect 19mm hose here

Connect hoses as shown (13mm hose to red barbed connector, 19mm hose to blue barbed connector), secure with jubilee clips and then feed hoses through duct to controller ensuring hoses are not kinked.

2

The controller must be installed in a well vented, dry and dust-free interior. Two 8mm holes must be drilled into the wall for assembly.

3

Secure the controller to the wall using the dowels and screws provided.

4

Position the compressor on the controller. Connect the compressor to the unit pipe using the 90-degree hose piece and hose clamps provided. Plug the compressor plug into the control socket.

5

Connect the air hoses to the nozzles on the controller (13mm hose to black nozzle and 19mm hose to blue nozzle) and secure with jubilee clips.

6

The controller requires its own, permanent adequately fused (13 amp) power supply. Fitted with an isolator switch for repair and maintenance.



7



To prevent fumes from the system entering the property via the service duct, please use blanking plug and connect the hoses accordingly.

8



For instructions on how to set the Date & Time, please refer to Document No. Graf-0005 Rev.1

9

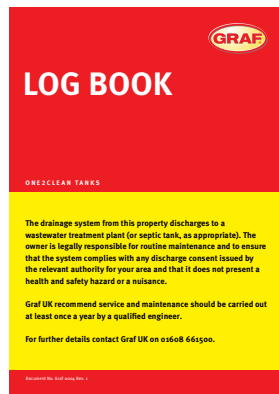

For all other information please refer to the One2Clean Log Book.

9

INSTALLATION OF AIR HOSES AND EXTERNAL CONTROLLER

* Must be installed within 18m of tank. (Air hoses are 20m in length)



1

Selecting the location

- The location must be protected from direct sunlight during the summer.
- The rear side of the cabinet must be installed with at least 10cm clearance from the nearest wall to allow for sufficient ventilation.
- The air hoses must be no longer than 20m.
- The cabinet must not be installed in ground water. This also applies to groundwater or backwater that occurs only occasionally.

2

Installing the cabinet in the ground and connecting the service duct

Excavate a hole of sufficient size for the cabinet (installation depth 50cm). Only coarse excavated soil that is free from stones may be used as backfill material is unsuitable, round gravel should be used (size 8-16mm). Make sure the cabinet is stable and is installed vertically in the excavation.

Push the 110mm pipe through the seal in the bottom of the cabinet. Fit a 45 degree bend to the end of the pipe inside the cabinet with the open end facing upwards.

3

Inserting the underground power supply cable

Drill a 20mm diameter hole in the side of the base section of the cabinet at a suitable position for the armoured power cable to feed through. Fit the M10 x 1.5mm cable gland (suitable for a cable diameter of 8-13mm).

4

Electrical connection

The electrical connection must only be carried out by a qualified electrician. An underground armoured cable must be laid to supply power to the cabinet. This cable must be protected by a 13 amp fuse from the building installation and must be fitted with an isolated switch for repair and maintenance. The underground cable is connected to the pre-assembled power socket in the cabinet. This power socket can be removed for easy assembly by unscrewing the two nuts from the holding plate.

5



Prior to installation of the control unit, ensure the spacer has been fitted to the back of the control unit.

6



The control unit should be mounted to the external cabinet with the screws and wing nuts provided.



7



Position the compressor on top of the control unit and connect together using the 90-degree hose piece and hose clamps provided.

8



Connect the air hoses to the nozzles on the controller (13mm hose to black nozzle and 19mm hose to blue nozzle).

9



Connect hoses as shown (13mm hose to red barbed connector, 19mm hose to blue barbed connector), secure with jubilee clips and then feed hoses through duct to controller ensuring hoses are not kinked.

10



Install a 90-degree bend on the inlet to the chamber and feed through the two hoses. Fit barbed connectors to each hose and secure with jubilee clip. Connect to underside of blanking plug.

11



Push blanking plug into end of 90-degree bend. Connect short lengths of hose to connectors on the blanking plug and the connect to appropriate barbed connectors on controller.

12



For instructions on how to set the Date & Time, please refer to Document No. Graf-005 Rev. 1. For all other information please refer to the One2Clean Log Book.

10 INSTALLATION OF THE EXTERNAL CONTROL CABINET (S)

Art. No. 107990



The points described in these instructions are to be respected without fail. If they are not respected, any claim under guarantee will be considered null and void. For all additional articles obtained by way of GRAF, you will be provided with separate installation instructions enclosed in the transport packing.

The components must be examined without fail for any damage before placing the unit in the trench.

Separate instructions will be provided for the operation and maintenance of the installation.

Contents

1.	Scope of supply and accessories	19
1.1	Scope of supply	19
1.2	Accessories required	19
2.	Choosing the location	19
3.	Installing the cabinet in the earth	20
3.1	Connecting the empty technical supply pipe to the clarification system	20
3.2	Introducing the earth cable for the power supply	20
3.3	Electrical connection	21
4.	Fitting the closure unit	22
5.	Fitting the one2clean control unit	22
5.1	Inserting the one2clean control unit	22
5.2	Connecting the air hoses	22
5.3	Fitting the GRAF empty pipe closure element made of PE foam material	23
6.	Dimensions	24

1. Scope of supply and accessories

1.1 Scope of supply

The external switch cabinet for EPP consists of the lower part and the cover hood with:

- Lock security pin with installation material
- 2 locking screws, M8, for fitting the one2clean control unit (wing nut and washer enclosed with the one2clean control unit).
- Cable screw connection M20x1.5 for power supply

1.2 Accessories required

The installation of the switch cabinet requires the following items:

- Empty pipe closure element, rated diameter 100 for the gas-tight closure of the technical connection pipe
- KG pipes, rated diameter 110, as technical connection pipe to the clarification system
- Earth contact coupling for the electrical connection of the control unit

2. Choosing the location

When choosing the location for the cabinet, the following points must be borne in mind:

- During the summer months the location should be protected from direct sunshine.
- The rear face of the cabinet must be placed with at least 10 cm of clear space from the nearest wall.
- Operation can be noisy! The air compressor produces a sustained noise of long duration when in operation (comparable to an oil heating fan or a freezer cabinet).
- The air hoses should not be longer than 20 metres.
- The switch cabinet must not be allowed to stand in ground water. This also applies to ground water or backed-up water which only occasionally occurs.
- Power supply is to be via a separately fused power connection (16 Ampere, time-lag). Any additional consuming components on the same fuse can interfere with operations.

The connection of the empty technical supply pipe is effected to the side of the cabinet with the aid of a cable connection socket with rated diameter of 110.

10 INSTALLATION OF THE EXTERNAL CABINET (S)

3. Installing the cabinet in the earth

The black venting outlet is to be fitted onto the cover of the cabinet.

An adequately large trench is to be dug, with the installation depth of the cabinet being 35 cm. The cabinet is then placed in the trench. As backfill material, only cohesive excavated soil may be used, free of any stones. In the event of the excavated material being unsuitable, round grain gravel (maximum granulation 8/16) is to be used.

Care must be taken to ensure that the cabinet is standing firmly and vertically upright in the excavation.

3.1 Connecting the empty technical supply pipe to the clarification system

The empty technical supply pipe is connected via a pipe plug with rated diameter of 110 to the socket provided for this purpose.

3.2 Introducing the earth cable for the power supply

The power cable is to be introduced into the cabinet by way of a M10x1.5 cable screw connection (suitable for cable diameters of 8-13 mm). A drill hole with diameter of 20 mm is to be provided for this purpose.

3.3 Electrical connection

The electrical connection of the switch cabinet may only be carried out by a qualified electrician.

The power supply requires an earth cable to be laid to the cabinet. **This cable must be fused with a 16 Amp fuse via the in-house installation, and must be capable of being isolated from the mains network.**

The connection for the control unit must be provided via a fused contact coupling to be provided by the client.

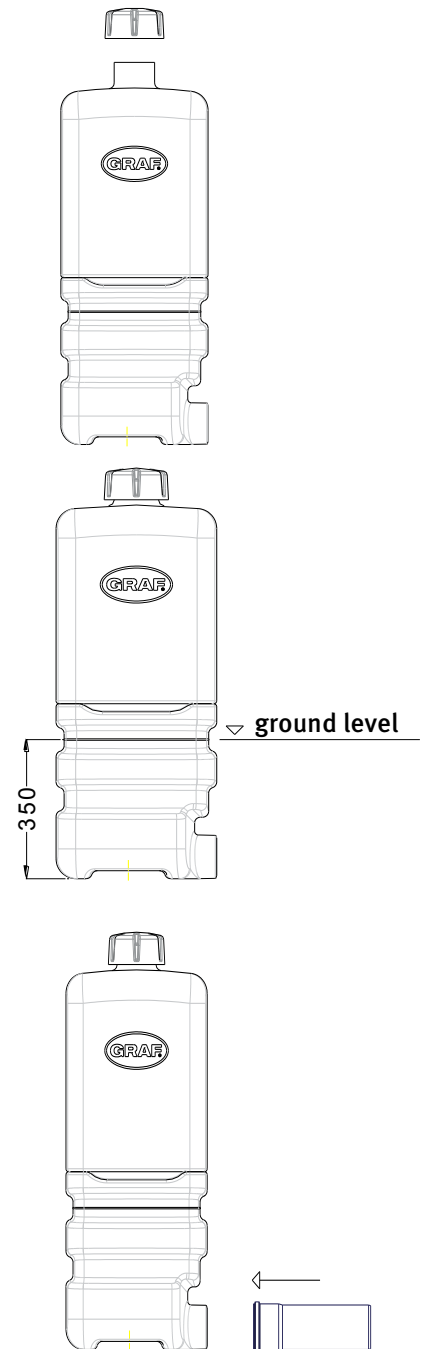

Provide fuse for the connection

10 INSTALLATION OF THE EXTERNAL CABINET (S)

4. Fitting the closure unit

The lock security pin is to be inserted through the cover from the inside to the outside. Securing is provided with the M4x12 screws.



10 INSTALLATION OF THE EXTERNAL CABINET (S)

5. Fitting the one2clean control unit

5.1 Inserting the one2clean control unit

The one2clean control unit is secured with the locking screws and wing nuts provided. For this purpose the screws are to be introduced from the outside into the interior.

The securing material which is enclosed with the one2clean control unit is not required.



5.2 Connecting the air hoses

The air hoses are conducted via the empty pipe laid in the earth to the planned location of the cabinet. The hoses are to be shortened in such a way that they are not under any tension and cannot be kinked.

The hoses are to be connected to the hose sockets on the control unit. For the fitting we recommend that the ends of the hoses be warmed.



The empty pipe must be closed off at least on the side of the control unit, so that any gas exchange by way of this pipe can be excluded (explosion protection, moisture, odours).

Close off the empty pipe

For this purpose we recommend the GRAF empty pipe connection made of PE foam material (Art. No. 107887).

10 INSTALLATION OF THE EXTERNAL CABINET (S)



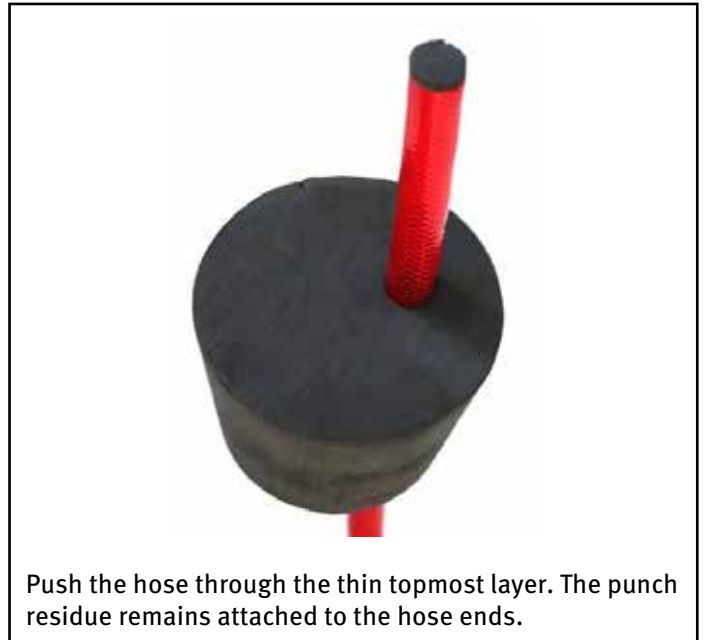





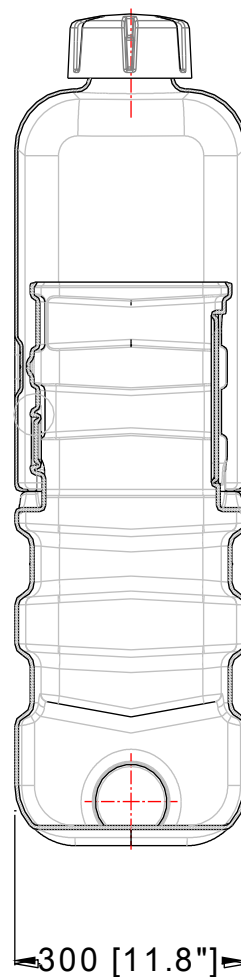
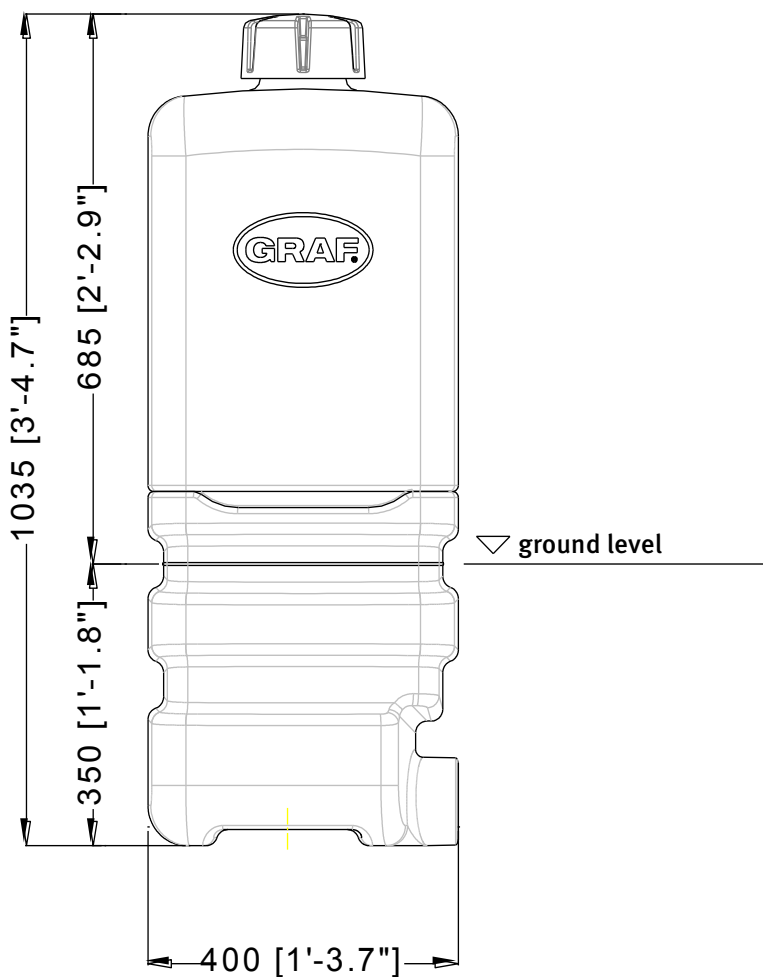
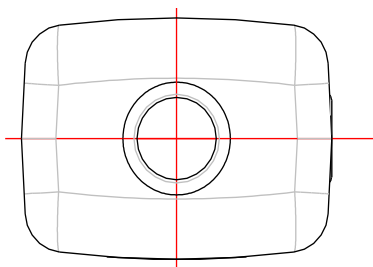



5.3 Fitting the GRAF empty pipe closure element made of PE foam material



10 INSTALLATION OF THE EXTERNAL CONTROL CABINET (S)

6. Dimensions



With unit turned on			Cycle pause rest: 684:44min
Press			
Press		X5	19:33:40 2014-05-21 we
Press			1□:33:59 2014-05-21
Press	 	To change hours to correct time	
Press		To move to minutes	09:3□:59 2014-05-21
Press	 	To change minutes to correct time	
Press		To move to date	09:11:59 201□-05-21
Press	 	To change the year	
Press		To move to month	09:11:59 2016:0□:21
Press	 	To change the month	
Press		To move to day	09:11:59 2016-01-2□
Press	 	To change the day	
Press		To store new settings	
Press		To go back to auto mode	



RAINWATER HARVESTING



STORMWATER MANAGEMENT



WATER BUTTS & COMPOSTERS



MULTIPURPOSE CONTAINERS



Graf UK Ltd
Regen House
Beaumont Road
Banbury
Oxfordshire OX16 1RH

T: 01608 661500
F: 01295 211333
E: info@grafuk.co.uk
www.grafuk.co.uk

Graf UK Ltd (Scotland)
220 Blairtummock Road
Queenslie Industrial Estate
Glasgow
G33 4ED

T: 0141 465 1540
F: 01295 211333
E: info@grafuk.co.uk
www.grafuk.co.uk