

600x600MM COVER
DOUBLE SEALED
C/W LOCKING SCREWS

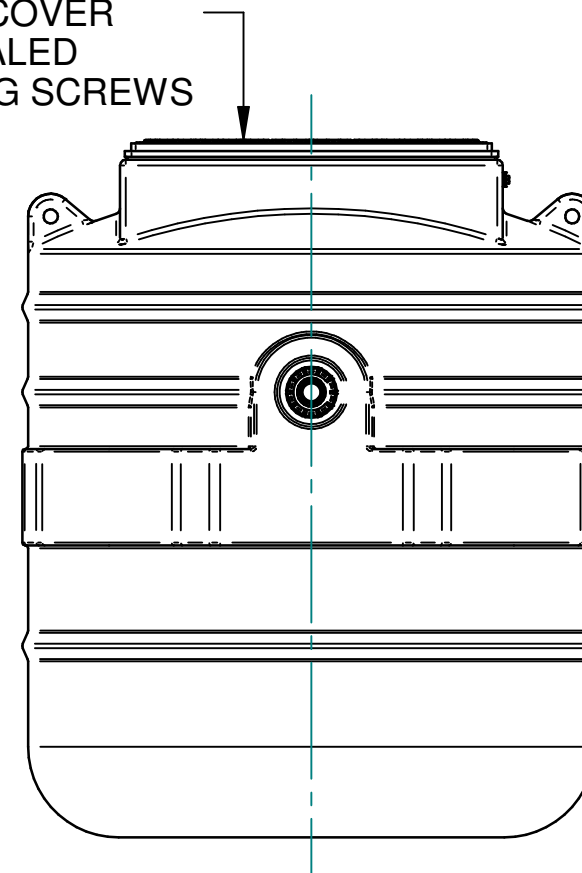

Available in single or twin pump configurations for rain water, effluent or sewage

Revision	Issue Date	ECN Reference

THE INFORMATION, DATA, AND DRAWINGS EMBODIED IN THIS DOCUMENT ARE STRICTLY CONFIDENTIAL AND ARE SUPPLIED WITH THE UNDERSTANDING THAT THEY WILL NOT BE DISCLOSED TO ANY THIRD PARTIES WITHOUT THE PRIOR WRITTEN CONSENT OF HARLEQUIN MANUFACTURING LTD

COPYRIGHT Sole property of Harlequin Manufacturing Ltd All rights reserved

UNLESS OTHERWISE SPECIFIED: DIMENSIONS ARE IN MM
LINEAR TOLERANCE \pm 0.25mm, ANGLES \pm 0.5°

DO NOT SCALE DRAWING - Use Figure Dimensions Only

IF IN DOUBT, ASK

TITLE: **800LT Pump Station**

NOTES:

DWG NO: 17-002-001	ISSUE DATE: 01/07/2020
REVISION: 00	DRAWN BY: JC
SHEET: 1 of 1	
FILE NAME: 800LT Pump Station.dft	

Harlequin
MANUFACTURING FOR TOMORROW

Harlequin Manufacturing Ltd
21 Clarehill Road
Moira
Co. Armagh
BT67 0PB
www.harlequin-mfg.com